

G300, G320

*Turn-mill centers for high-performance
machining of medium-sized workpieces*

INDEX



better.parts.faster.

New dimensions in turning and milling

The INDEX G300/G320 is an innovative turn-mill center in a class of its own – especially when it comes to efficient production of medium-sized workpieces with high complexity and variance.

Based on a rigid and vibration-damping mineral-cast monoblock machine bed and large-dimension linear guides in X and Z axes, this series stands for modern mechanical engineering

and thus for excellent machining results with high productivity. Three tool carriers with a tool pool of up to 141 tools provide maximum flexibility for complete machining of complex workpieces.

A total of up to 16 productive axes ensure impressive machining results without exception.



The large work area is unique in this class and impresses with its sophisticated features that allow simultaneous machining using all three tool carriers with no collision risk.

The smooth and steeply sloping stainless steel interior paneling ensures optimum chip flow. The chip conveyor can be mounted on the right or left side, depending on customer requirements.

The INDEX G300/G320 is relied on for the manufacture of a wide range of products in many industries such as machinery construction, automotive, and aerospace.

The machine concept

- Identical main and counter spindles with spindle clearance \varnothing 102 mm
- Chuck up to \varnothing 250 (\varnothing 315 mm)
- 3 tool carriers for up to 141 tools
- Powerful motor milling spindle with proven Y/B quill kinematics for complex 5-axis milling operations (G320)
- Sophisticated work area concept for turning lengths up to 1,400 mm and variable machining options
- High thermal and mechanical stability
- High acceleration and fast rapid traverse rates up to 50 m/mm
- Engineering excellence "Made in Germany"



Best performance for applications in the automotive, aerospace, and machinery industries

INDEX provides optimal solutions for flexible and efficient production. Throughout the prodecut development process, INDEX engineers leverage years of experience from many industries. Products and processes are then tailored to specific customer needs through feasibility studies, efficiency

analyses and, above all, close collaboration with the customer. Due to the modular design and high flexibility of INDEX products, customers receive a solution perfectly matched to their application.

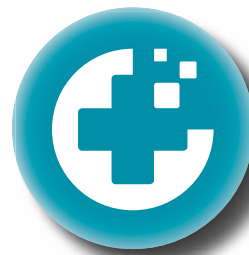

Motor housing

Steel
 98 mm x 125 mm

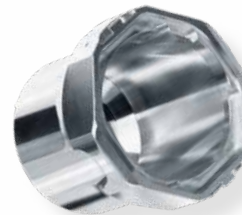

Cup

Aluminum
 110 mm x 120 mm



Tractor rear axle shaft

Steel
 390 mm x 486 mm





Centrifuge

Aluminum
 200 mm x 60 mm

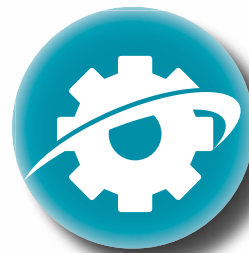
The INDEX G300 and INDEX G320 turn-mill centers offer the best performance for customers from the machinery, automotive, and aerospace industries. Providing an ideal combination of productivity, flexibility and process reliability, the machine is a complete solution for high-performance machining of large workpieces.





Rotor carrier

 Steel
 140 mm x 285 mm





Nut housing

 Steel
 64 mm x 154 mm





Bearing flange

 Steel
 129 mm x 136 mm



Planetary gear for cutting machine

 Steel
 273 mm x 76 mm

Complete machining based on a modular system

The modular system in this series offers a wide range of options. Up to 3 tool carriers can be integrated into the work area, and all of them can be equipped with a Y axis.

The work area offers ample space to machine any kind of workpiece, accommodating medium-sized parts up to 1,400 mm in length.

The powerful main and counter spindles are designed for bar diameters up to 102 mm and for chuck part diameters of up to 315 mm.

Turret steady rests are available for machining long or shaft-type parts.

The INDEX G320 features a powerful motor milling spindle capable of simultaneous 5-axis machining.

The ergonomic setup and operating concept played a major role in the new design.

All the relevant components are easily accessible for operating and maintenance personnel. Optionally, an integrated workpiece handling system matched to the machining processes can be used for loading and unloading shaft and flange parts.

Furthermore, the modular robot cell iXcenter is available for all machines in this series, for flexible feeding and discharging of blanks and finished parts.

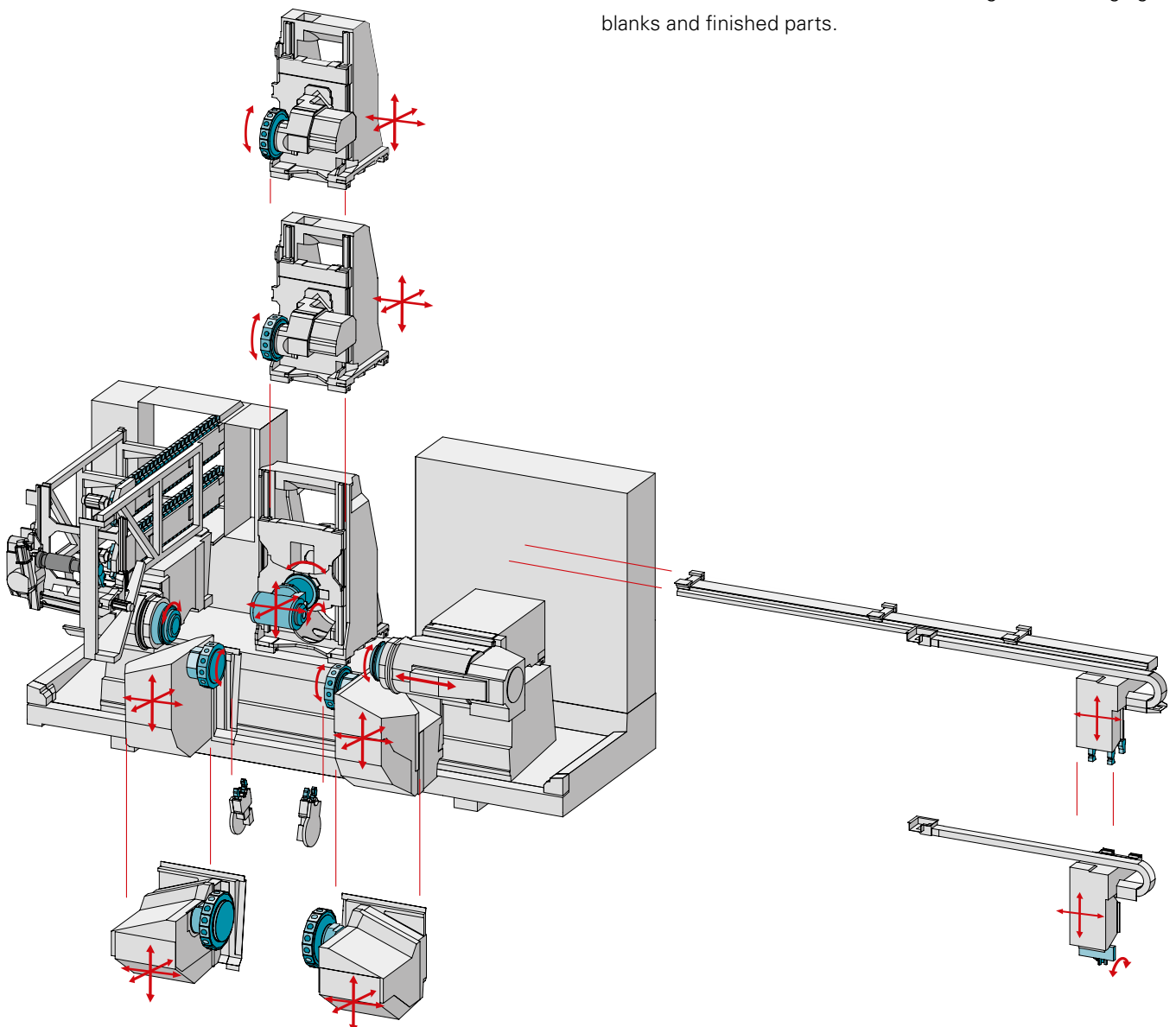



The components

Main and counter spindles

- Spindle clearance: Ø 102 mm
- Max. speed: 4,000 rpm
- 59 kW, 715 Nm (40% DC)
- Chuck diameter: Ø 250 mm (Ø 315 mm)

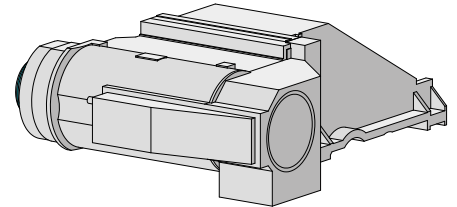
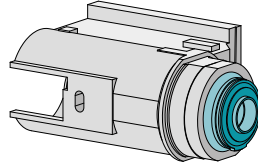

Upper turret with 12 stations (INDEX G300)

- 12 live stations, each VDI 40 with W-serration
- 5,400 rpm, 12 kW, 30 Nm (25% DC)
- X axis: 280 mm, rapid traverse rate 30 m/min
- Y axis: +/-80 mm, rapid traverse rate 20 m/min
- Z axis: 1,400 mm, rapid traverse rate 50 m/min

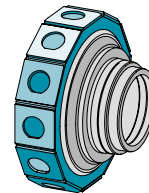

Two turrets with 12 stations each

- 12 live stations each, VDI 40 with W-serration
- 5,400 rpm, 12 kW, 30 Nm (25% DC)
- X axis: 180 mm, rapid traverse rate 30 m/min
- Y axis: +/-60 mm, rapid traverse rate 20 m/min
- Z axis: 1,400 mm, rapid traverse rate 50 m/min

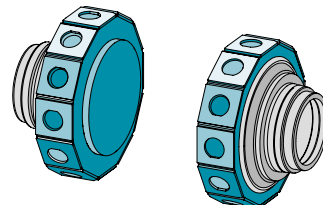

Motor milling spindle (INDEX G320)

- HSK-T63: 18,000 rpm/12,000 rpm, 72 Nm/95 Nm (25% DC)
- Capto-C6: 18,000 rpm/12,000 rpm, 72 Nm/95 Nm (25% DC)
- X axis: 580 mm, rapid traverse rate 30 m/min
- Y axis: +135 mm/-115 mm, rapid traverse rate 20 m/min
- Z axis: 1,400 mm, rapid traverse rate 50 m/min
- B axis: -25°/+205°, rapid traverse rate 90 rpm

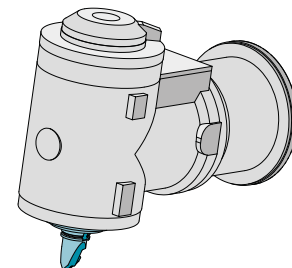

Tool magazine (INDEX G320)

- Single-row: 56 tool locations HSK-T 63/Capto-C6
- Double-row: 111 tool locations HSK-T 63/Capto-C6
- Max. tool weight: 8 kg
- Max. tool diameter: 125 mm
- Max. tool length: 400 mm
- Setup station

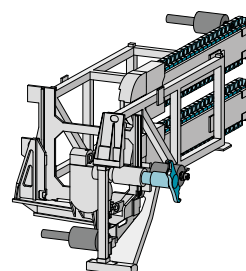

Lower turret steady rests (optional)

- Clamping range: 20 – 101 mm

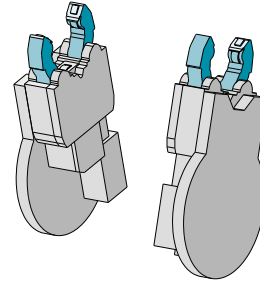

Workpiece handling unit for shafts (optional)

- Integrated 2-axis workpiece handling unit
- Max. workpiece diameter: 120 mm
- Max. workpiece length: 800 mm
- Max. workpiece weight: 20 kg

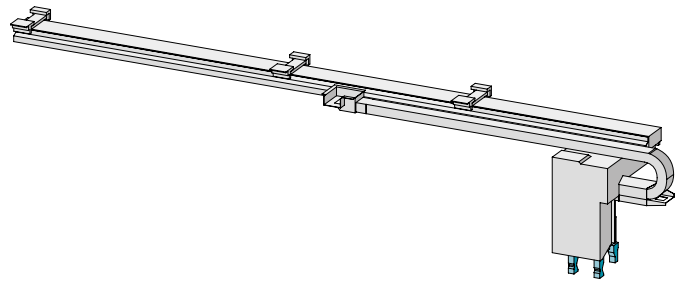

Workpiece handling unit for flanges (optional)

- Integrated 3-axis workpiece handling unit
- Max. workpiece diameter: 200 mm
- Max. workpiece length: 150 mm
- Max. workpiece weight: 20 kg

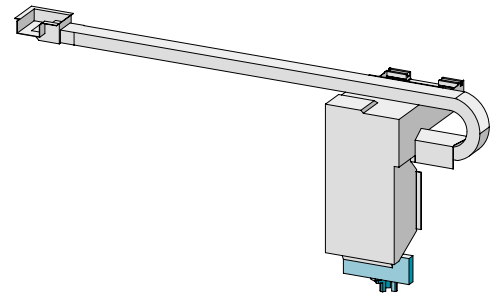

Upper turret with 15 stations (INDEX G300 optional)

- 15 live stations, each VDI 30 with W-serration
- 7,200 rpm, 12 kW, 25 Nm (25% DC)
- X axis: 280 mm, rapid traverse rate 30 m/min
- Y axis: +/-80 mm, rapid traverse rate 20 m/min
- Z axis: 1,400 mm, rapid traverse rate 50 m/min

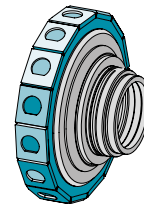

Two lower turrets with 15 stations each (optional)

- 15 live stations, each VDI 30 with W-serration
- 7,200 rpm, 12 kW, 25 Nm (25% DC)
- X axis: 180 mm, rapid traverse rate 30 m/min
- Y axis: +/-60 mm, rapid traverse rate 20 m/min
- Z axis: 1,400, rapid traverse rate 50 m/min

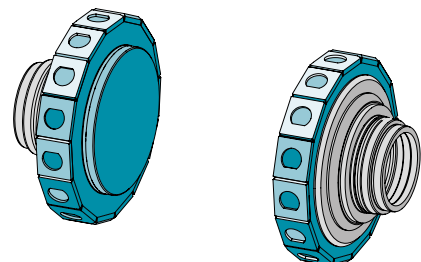

Large degrees of freedom in the work area for a wide variety of machining options

INDEX G320

Maximum productivity by simultaneous machining with 3 tools

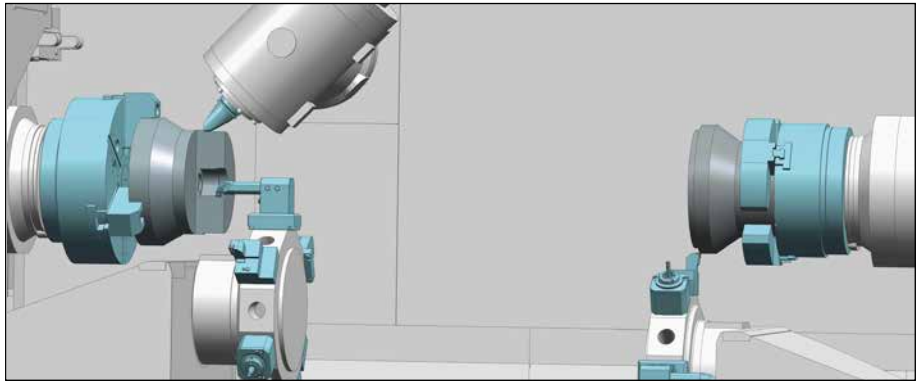

INDEX G320

Use of tools up to 400 mm long in the motor milling spindle, e.g., for deep-hole drilling applications with the highest precision.

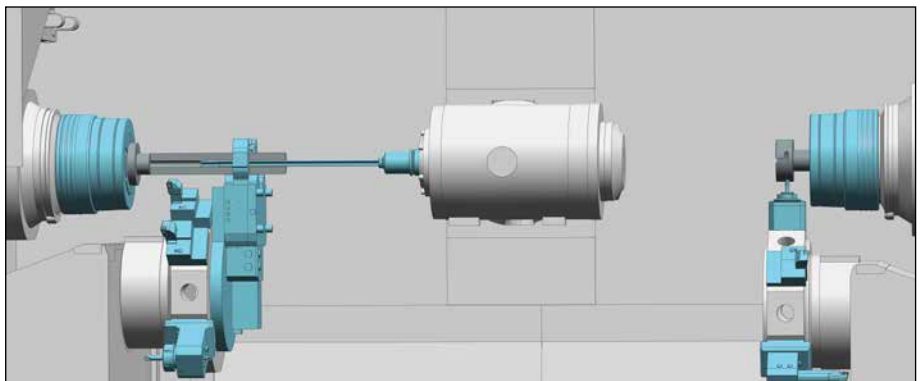

INDEX G300

Flexible shaft machining through the use of turret steady rests

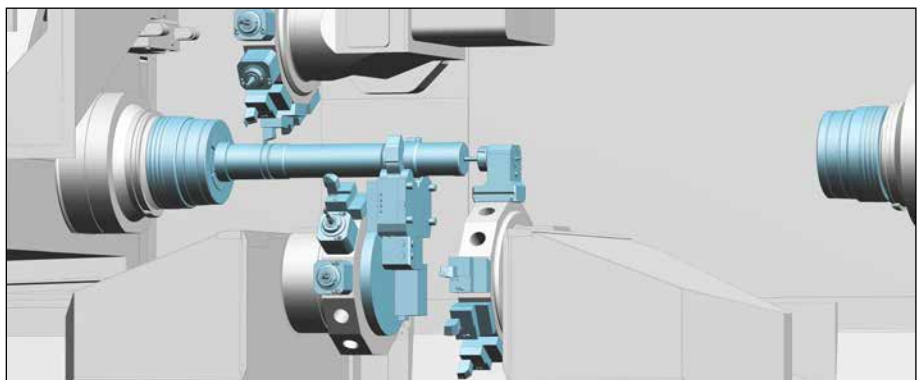

INDEX G300, G320

Maximum freedom from collisions due to submergence of the lower tool carriers.

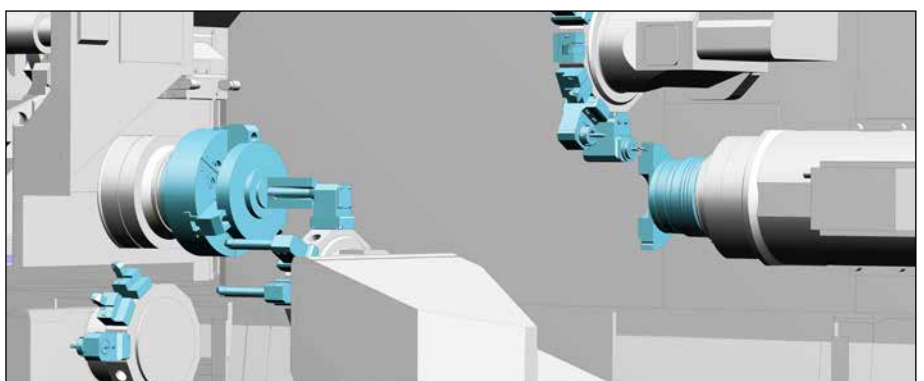





Motor milling spindle

HSK-T63 or Capto-C6

Y-B quill

with torque motor for high precision



Tool magazine

with up to 111 tool locations HSK-T63/Capto-C6



Main spindle

Ø 102 mm/4,000 rpm/
525/715 Nm (100/40% DC)



Worktable

with torque motor

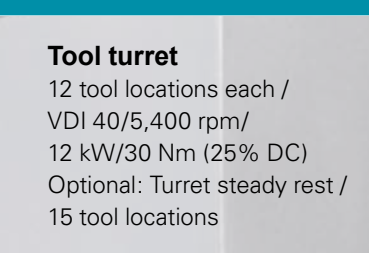

Tool turret

12 tool locations each /
VDI 40/5,400 rpm/
12 kW/30 Nm (25% DC)
Optional: Turret steady rest /
15 tool locations

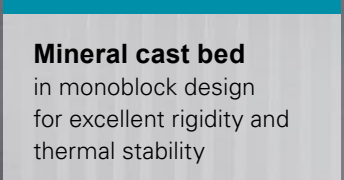

Mineral cast bed

in monoblock design
for excellent rigidity and
thermal stability

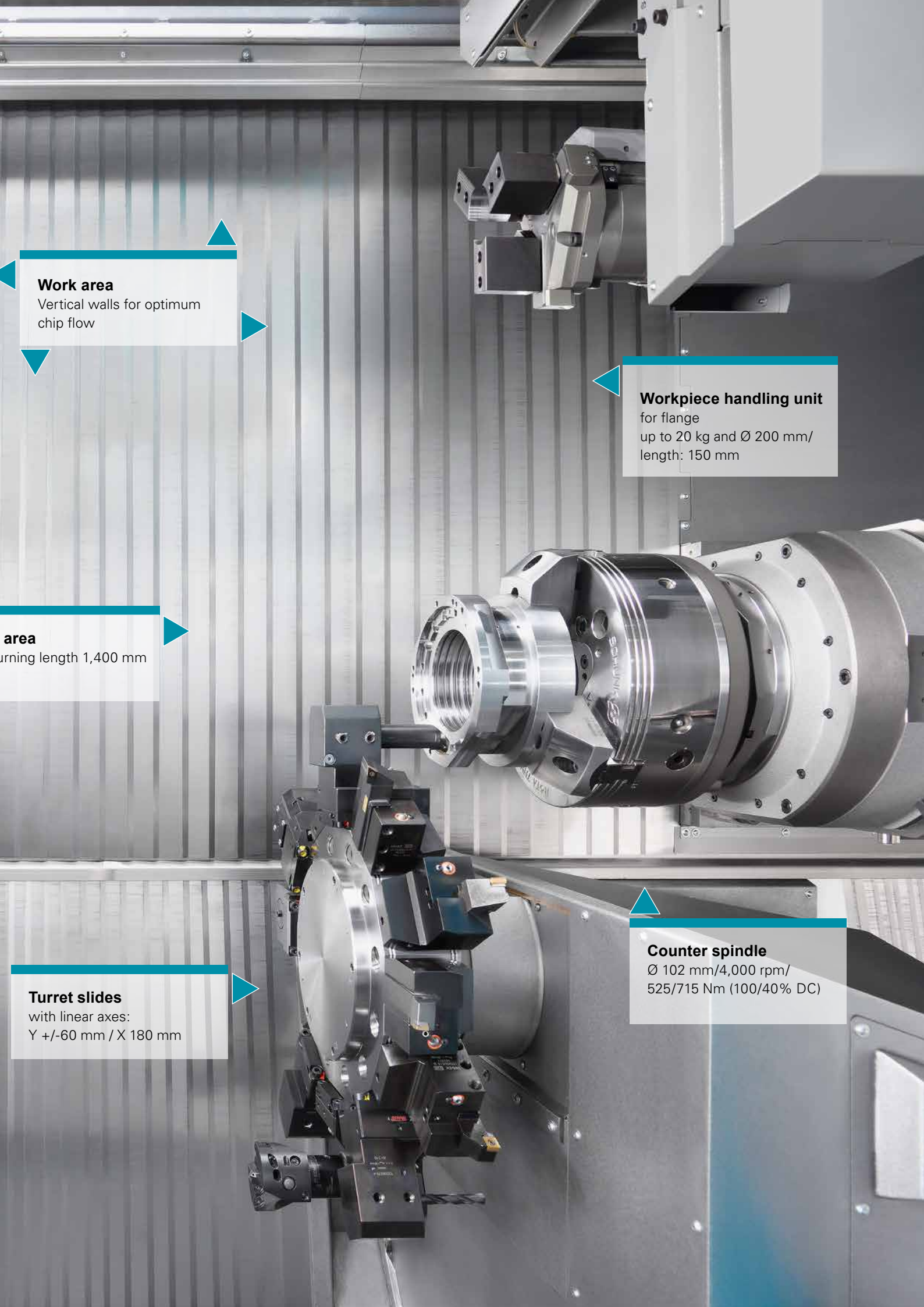

Work area

Vertical walls for optimum chip flow

Workpiece handling unit

for flange
up to 20 kg and Ø 200 mm/
length: 150 mm

Work area

turning length 1,400 mm

Turret slides

with linear axes:
Y +/-60 mm / X 180 mm

Counter spindle

Ø 102 mm/4,000 rpm/
525/715 Nm (100/40% DC)

The cooling concept: efficient use of energy

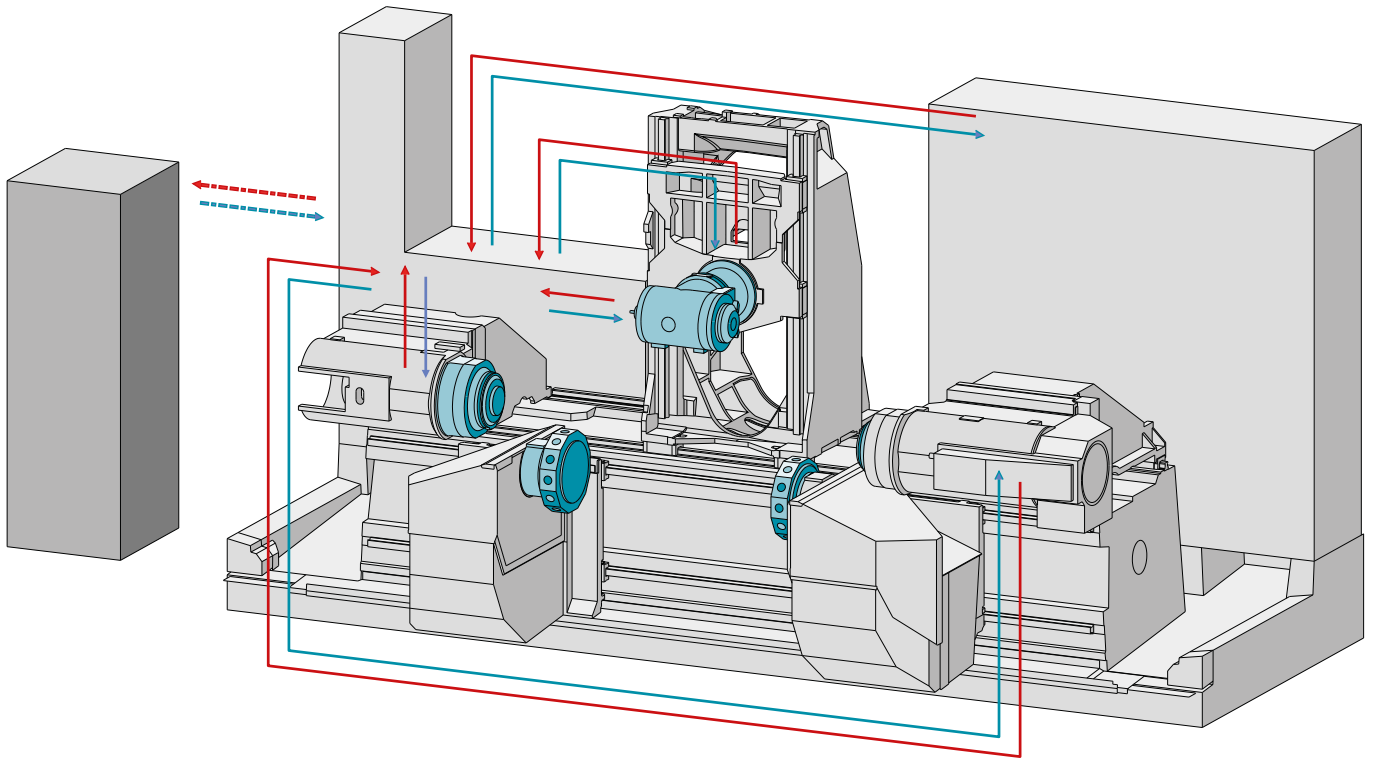

Intelligent use of proven cooling principles:

- **Targeted heat dissipation**

All heat-loss sources of the INDEX G300/G320 are cooled directly with different cooling media via multiple fluid circuits. The main spindle, counter spindle, tool carrier, hydraulic system and control cabinet each have a separate cooling circuit. The coolant directly absorbs lost heat energy and removes it from the machine.

- **Climate-neutral dissipation of heat**

If there is not an immediate use for the heat energy, the INDEX cold water interface provides the ability to dissipate it in a climate-neutral manner. By actually removing the head instead of just transferring it to the surrounding facility, a company can reduce the cost of its overall climate control.

- **Economical use of waste heat**

The INDEX cold-water interface collects all of the heat loss energy in a central location where it can be recycled for another use. The captured energy can be applied to heating the facility, service water heating or process heating for other production steps. The recovery of machine waste heat enables a sustainable reduction of energy costs.

Integrated automation solutions for efficient production



The integrated workpiece handling unit is available as an option. It can be used equally for loading and unloading as well as for the removal of remnants and is designed for parts weighing up to 20 kg and with a diameter of up to 120 mm (shaft) or 200 mm (flange). The handling unit is equipped with 2 or 3 CNC axes that are operated from the machine control.

Further individual automation solutions, such as conveyor belts or robot handling with ancillary functions can be integrated on a customer-specific basis.

Removal of finished parts (or feeding) using a workpiece-specific gripper for shaft or flange parts

2-axis workpiece handling system moves to the removal point without collision



3-axis workpiece handling for flange parts

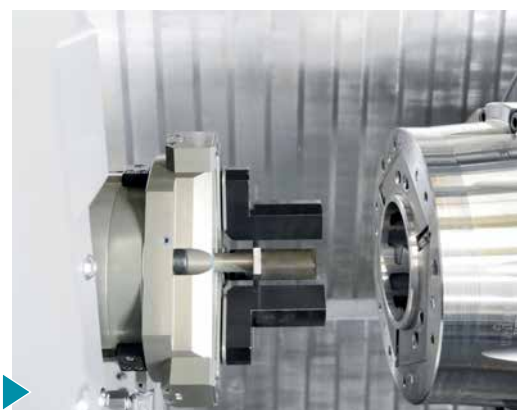

Robot cell *Xcenter*

Intelligent automation – even more flexibility and efficiency

With the iXcenter robot cell, blanks and finished parts can be fed and discharged quickly, safely, and flexibly. The overall sequence between the machine and the robot cell is created using predefined macros in the NC program. The sliding door in the machine's work area access is provided to the robot via a sliding door which opens and closes automatically and the unit's modular design offers the flexibility to integrate various processes. The iXcenter's ease of access to spindles, tool carriers, and tool magazine makes you fully prepared to set up the machine.

Your benefits

- Automatic and ergonomic workpiece feeding and discharge
- Modular basic cell that allows flexible expansion
- Low-manned continuous operation is possible
- Door designed for optimum access and view of the machine
- Compact design
- Modern INDEX machine design
- Entire system from one source

Technical data

- 6-axis robot with 165 kg load capacity
- Reach 2,660 mm





Unlock more potential

Integration of downstream processes by attaching specialized modules

- Pallet/rack modules
- Storage systems
- Circulating conveyors
- Cleaning stations
- Deburring modules
- Laser marking modules
- Measuring units
- Test modules
- Discharge units
- Additional customer-specific solutions

Add on any configuration options available for the machine

- Internal handling (flange and shaft)
- Bar loading magazines
- Chip conveyors arranged left/right

Options available for the basic cell

- 6-axis robot with up to 270 kg load capacity
- Double grippers in flange and shaft versions
- Automatic gripper change, including gripper storage





The cockpit for easy integration of the machine in your business organization



Focus on production and control – Industry 4.0 included.

The iXpanel operating concept provides access to networked production. With iXpanel, your operator always has all relevant information for efficient production right at the machine. iXpanel is included with the standard version and can be enhanced with custom options. You can use iXpanel just as you require it for your business organization – that's Industry 4.0 tailored to suit your needs.

Future-proof.

iXpanel integrates the latest control generation SIEMENS Sinumerik 840D solution line. Use iXpanel intuitively via an 18.5" touchscreen monitor.

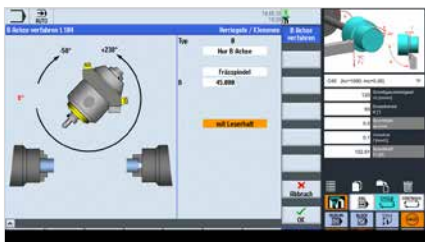

Productive.

Maximum performance through comprehensive technology cycles and programming screens, e.g., for optimum turning, milling and drilling, especially when using several tools simultaneously.



Intelligent.

The machine always starts with the control home screen. Other functions can be displayed on a second screen at any time, and operators can enjoy direct, activity-related assistance already with the standard version, such as workpiece drawings, setup lists, programming aids, documentation, etc., and all this right at the machine.

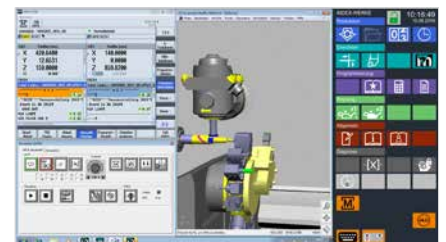

Virtual & open.

With the optional VPC box (industrial PC), iXpanel opens up the world of the Virtual Machine with the 3 operating modes

- CrashStop
- RealTime mode
- Independent simulation (VM on board) directly in the control system.

Thanks to the VPC box, the machine can be integrated into your IT structure without any restrictions.



18.5" TOUCHSCREEN MONITOR

STANDARD included as standard

OPTION

Industry 4.0 features

Order documents	Customer data	Workpiece counter	Production status	Drawings	Setup sheet	VPC Box	Virtual machine 3D simulation
Notes	Information center	Maintenance & care	User management	Technology computer	Programming help	VirtualPro programming studio	Custom applications

+ many more standard features

INDEX G300, G320

INDEX G320 work area (with tool turret 15 x VDI 30)

Dimensions in mm

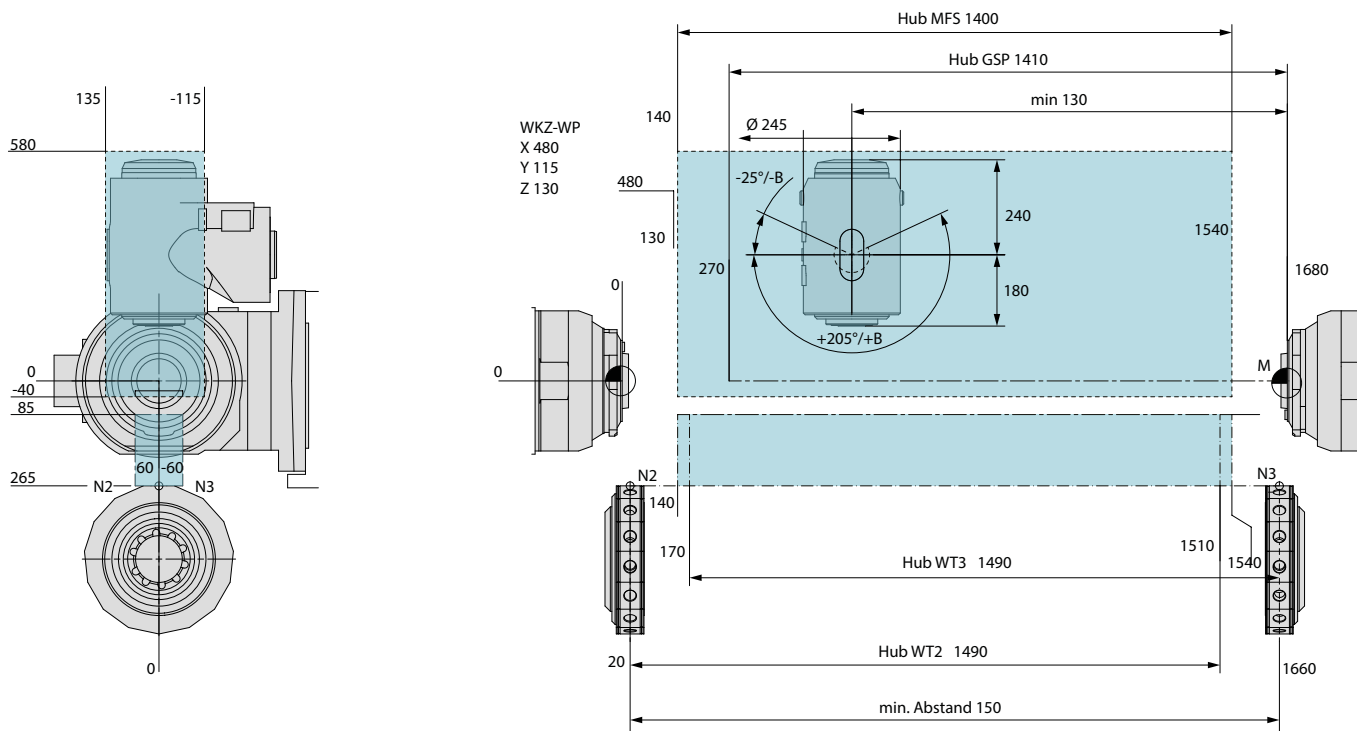

INDEX G320 work area (with tool turret 12 x VDI 40)

Dimensions in mm

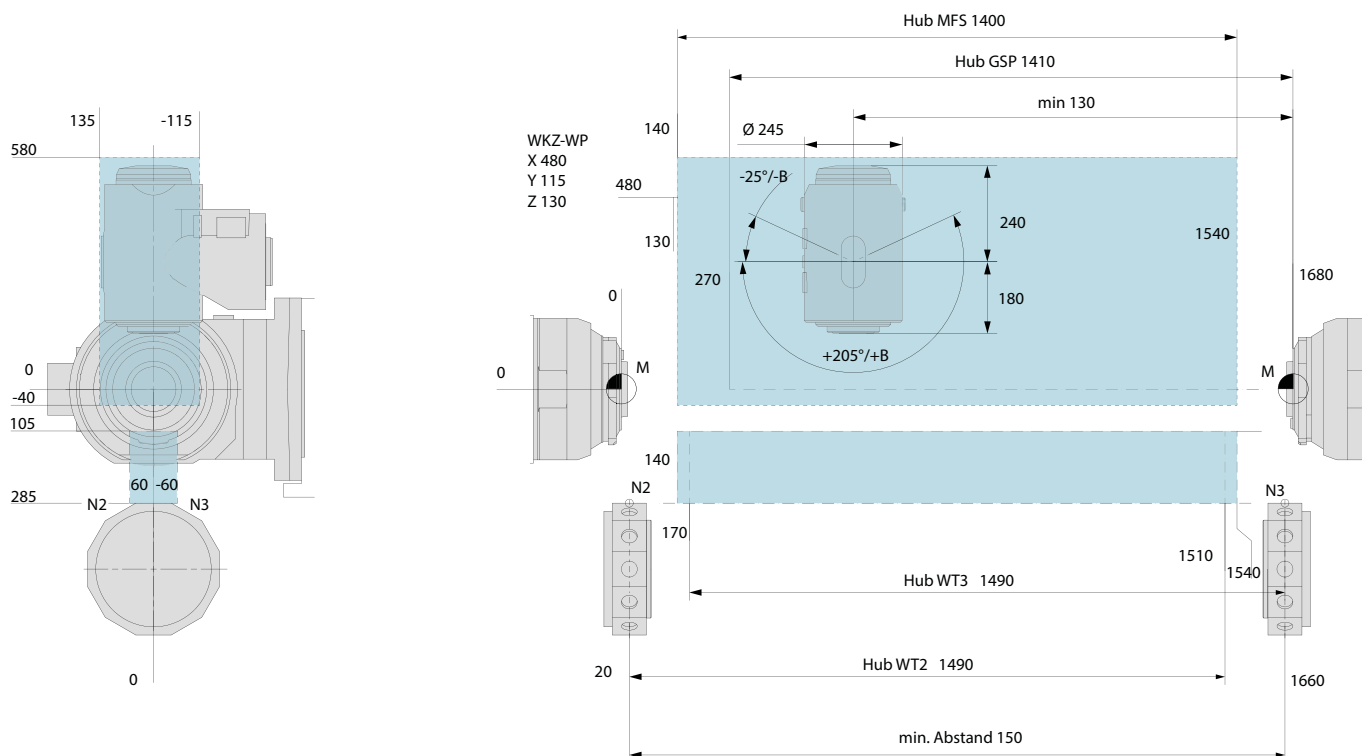

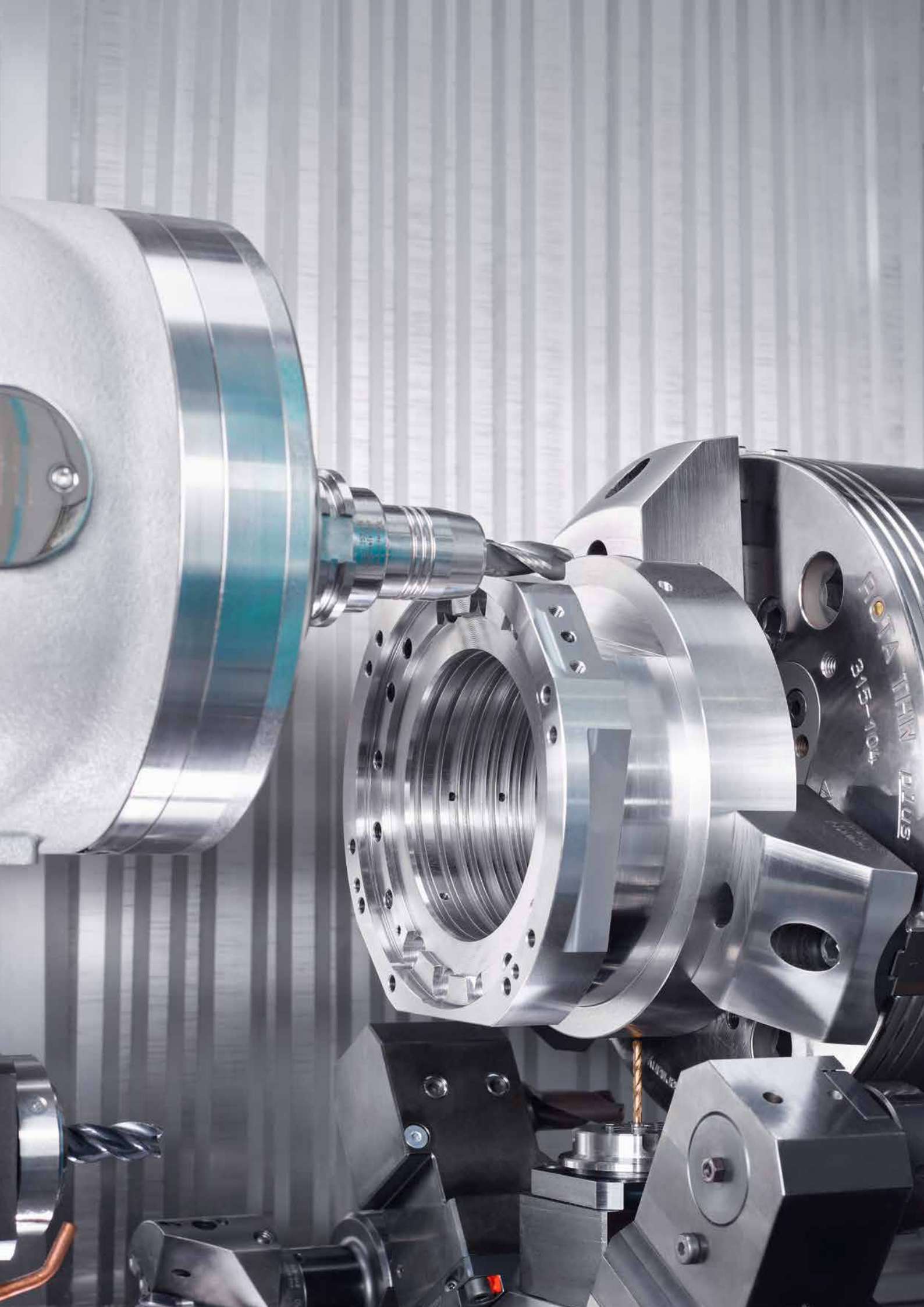

INDEX G300, G320

Installation plan for INDEX G300/G320

Turning length 1,400 mm /
chip conveyor at left and workpiece handling

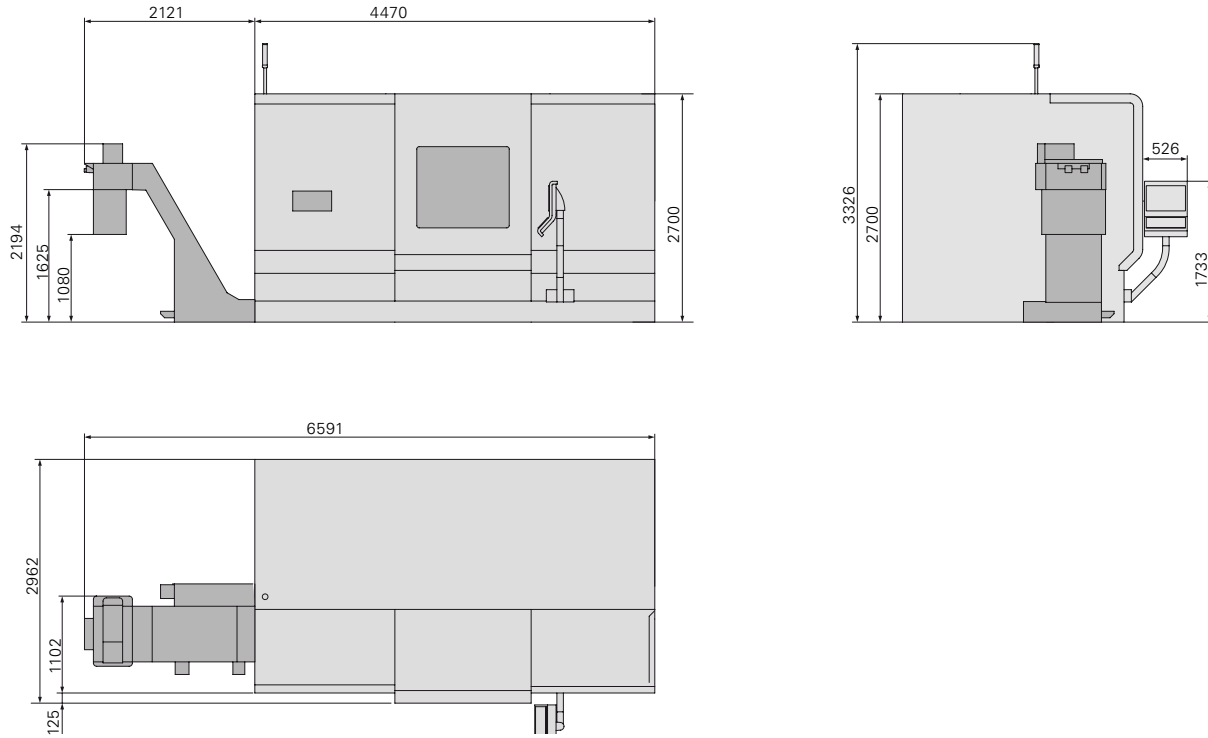

Installation plan for INDEX G300/G320

Turning length 1,400 mm / chip conveyor at right
iXcenter with basic cell and pallet module

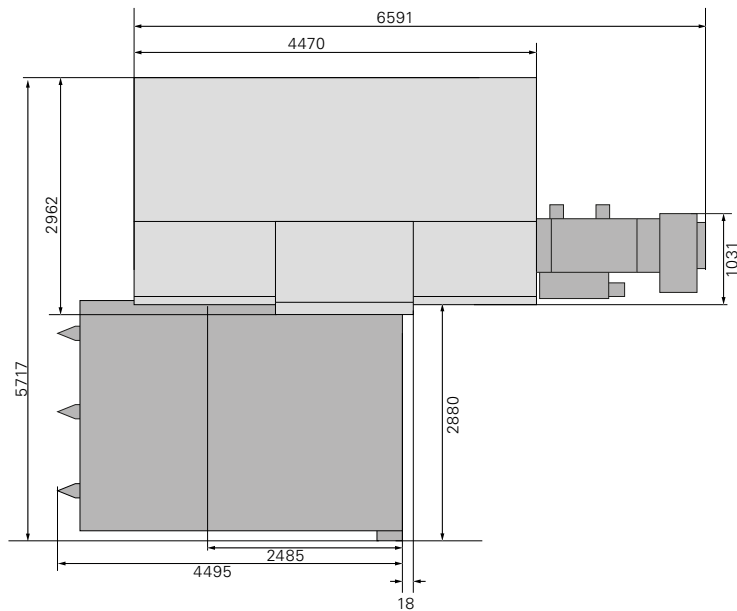

Technical data

		INDEX G300	INDEX G320
Work area			
Turning length	mm	1400	1400
Main spindle and counter spindle			
Spindle clearance	mm	102	102
Spindle nose ISO 702/1		A8	A8
• Max. speed	rpm	4000	4000
• Drive power (100%/40% DC)	kW	44/59	44/59
• Torque (100%/40% DC)	Nm	525/715	525/715
Chuck diameter	mm	250 (315)	250 (315)
C axis resolution	deg.	0.001	0.001
Upper tool carrier			
		Turret	Motor milling spindle
Kinematics		XYZ	XYZB
Tooling system		VDI30 // VDI40	HSK-T63 // Capto-C6
Number of stations		15 // 12	
• Max. speed	rpm	7,200 // 5,400	18,000/12,000 // 18,000/12,000
• Drive power (100% DC)	kW	12 // 12	16/16.6 // 16/16.6
• Torque (25% DC)	Nm	25 // 30	72/95 // 72/95
X slide travel, rapid traverse rate, feed force	mm / m/min / N	280/30/9,000	620/30/9,000
Y slide travel, rapid traverse rate, feed force	mm / m/min / N	+/-80/20/10,000	+135/-115 // 20 // 10.000
Z rapid traverse rate, feed force	m/min / N	50/10,000	50/10,000
B axis swivel range, rapid traverse rate	degrees/rpm		-25/+205 (+/- 115)/90
Tool carrier, bottom left/right			
		Turret XYZ	Turret XYZ
Tooling system DIN 69880		VDI30 // VDI40	VDI30 // VDI40
Number of stations (live), turret XYZ/XZ		15 // 12	15 // 12
• Max. speed	rpm	7,200 // 5,400	7,200 // 5,400
• Drive power	kW	12 // 12	12 // 12
• Torque (25% DC)	Nm	25 // 30	25 // 30
X slide travel, rapid traverse rate, feed force	mm / m/min / N	180/30/9,000	180/30/9,000
Y slide travel, rapid traverse rate, feed force	mm / m/min / N	+/-60/20/10,000	+/-60/20/10,000
Z slide travel, rapid traverse rate, feed force	mm / m/min / N	1,400/50/10,000	1,400/50/10,000
Tool magazine			
Tooling system			HSK-T63 / Capto-C6
Tool magazine locations	(1 chain/2 chains)		56/111
Max. tool weight	kg		8
Max. tool diameter	mm		125
Max. tool length	mm		400
Max. tilting torque	Nm		12
Turret steady rest (optional)			
Turret steady rest clamping range (with chip guard)	mm	20 - 101	20 - 101
Workpiece handling unit for shaft/flange (optional)			
Workpiece weight, shaft/flange	kg	20/20	20/20
Max. workpiece diameter, shaft (for discharge)	mm (dia./length)	120/800	120/800
Max. workpiece diameter, flange (feeding/discharge)	mm dia./length	200/150	200/150
General data			
Length x width x height	mm	4,350 x 2,900 x 2,700	4,350 x 2,900 x 2,700
Weight	t	23	23
Connected power	kW	112	112
Control		Siemens S840D sl	Siemens S840D sl

BRAZIL | Sorocaba
INDEX Tornos Automaticos Ind. e Com. Ltda.
Rua Joaquim Machado 250
18087-280 Sorocaba - SP
Phone +55 15 2102 6017
info@index-traub.com.br
www.index-traub.com.br

CHINA | Shanghai
INDEX Trading (Shanghai) Co., Ltd.
No. 526, Fute East 3rd Road
Shanghai 200131
Phone +86 21 54176637
info@index-traub.cn
www.index-traub.cn

CHINA | Taicang
INDEX Machine Tools (Taicang) Co., Ltd.
1-1 Fada Road, Building no. 4
Ban Qiao, Cheng Xiang Town
215413 Taicang, Jiangsu
Tel.: +86 512 5372 2939
info@index-traub.cn
www.index-traub.cn

DENMARK | Langeskov
INDEX TRAUB Danmark
Havretoften 1
5550 Langeskov
Phone +45 30681790
info@index-traub.dk
www.index-traub.dk

GERMANY | Esslingen
INDEX-Werke GmbH & Co. KG Hahn & Tessky
Plochingen Strasse 92
73730 Esslingen
Tel. +49 711 3191-0
info@index-werke.de
www.index-werke.de

GERMANY | Deizisau
INDEX-Werke GmbH & Co. KG Hahn & Tessky
Plochingen Strasse 44
73779 Deizisau
Tel. +49 711 3191-0
info@index-werke.de
www.index-werke.de

GERMANY | Reichenbach
INDEX-Werke GmbH & Co. KG Hahn & Tessky
Hauffstrasse 4
73262 Reichenbach
Tel. +49 7153 502-0
info@index-werke.de
www.index-werke.de

FINLAND | Helsinki
INDEX TRAUB Finland
Hernepellontie 27
00710 Helsinki
Phone +358 10 843 2001
info@index-traub.fi
www.index-traub.fi

FRANCE | Paris
INDEX France S.à.r.l
12 Avenue d'Ouessant / Bâtiment I
91140 Villebon-sur-Yvette
Phone +33 1 69 18 76 76
info@index-france.fr
www.index-france.fr

FRANCE | Bonneville
INDEX France S.à.r.l
399, Av. de La Roche Parnale
74130 Bonneville Cedex
Phone +33 4 50 25 65 34
info@index-france.fr
www.index-france.fr

NORWAY | Oslo
INDEX TRAUB Norge AB
Liadammen 23
1684 Vesterøy
Phone +47 93080550
info@index-traub.se
www.index-traub.no

RUSSIA | Togliatti
INDEX RUS
Lesnaya Street 66
445011 Togliatti
Phone +7 848 269 16 00
info@index-rus.ru
ru.index-traub.com

SWEDEN | Stockholm
INDEX TRAUB Nordic AB
Fagerstagatan 2
16308 Spånga
Phone +46 8 505 979 00
info@index-traub.se
www.index-traub.se

SWITZERLAND | St-Blaise
INDEX Werkzeugmaschinen (Schweiz) AG
Av. des Pâquiers 1
2072 St-Blaise
Tel. +41 32 756 96 10
info@index-traub.ch
www.index-traub.ch

SLOVAKIA | Malacky
INDEX Slovakia s.r.o.
Vinohrádok 5359
901 01 Malacky
Phone +421 34 286 1000
info@index-traub.sk
www.index-traub.sk

U.S.A. | Noblesville
INDEX Corporation
14700 North Pointe Boulevard
Noblesville, IN 46060
Phone +1 317 770 6300
info@index-usa.com
www.index-usa.com

Visit us on our social media channels:



better.parts.faster.

INDEX
TRAUB

**INDEX-Werke GmbH & Co. KG
Hahn & Tessky**

Plochingen Strasse 92
73730 Esslingen

Phone +49 711 3191-0
Fax +49 711 3191-587
info@index-werke.de
www.index-werke.de

